

# CONTENTS

1 · INSTALLATION	安裝	1
2 · MOTOR AND BELT	馬達與皮帶	3
3 · LUBRICATION	潤滑油	3
4 · CHANGE OF LUBRICATION OIL	潤滑油的更換	4
5 · REPLACING OIL FILTER	濾油器之更換	5
6 · HOW TO REPLACE THE NEEDLES	擊針的選用及更換方式	5
7 · THREADING	穿線方式	6
8 · ADJUSTING THREAD TENSION	拉線鬆緊度的調整	7
9 · ADJUSTING OF TOP COVER THREAD EYELET	上飾線控線桿的調整	7
10 · ADJUSTING PRESSER FOOT	壓腳的調整	8
11 · ADJUSTING PRESSURE OF PRESSER FOOT	壓腳壓力強度的調整	8
12 · ADJUSTING STITCH LENGTH	縫目長度的調整	9
13 · ADJUSTING DIFFERENTIAL FEED RATIO	差動比的調整	9
14 · ADJUSTING HEIGHT NEEDLE BAR	針棒高度的調整	10
15 · POSITION NEEDLE AND LOOPER	針與勾針位置的說明	11
16 · ADJUSTING TIMING RELATION BETWEEN NEEDLES AND LOOPER	針與勾針的時位關係調整	12
17 · ADJUSTING THE HEIGHT OF REAR NEEDLE GUARD	頂針片高度之調整	14
18 · ADJUSTING FRONT AND REAR NEEDLE GUARD	前後頂針片之調整	14
19 · ADJUSTING THE HEIGHT OF FEED DOG	送布齒高度調整	15
20 · ADJUSTING THE POSITION OF THE SPREADER	上叉位置的設定	16
21 · FIXING TOP COVER THREAD GUIDE & TOP COVER THREAD EYELET	上飾線之導線器的固定	17
22 · THE POSITION OF LOOPER THREAD TAKE-UP	勾針控制線桿的位置	18
23 · THE RELATIVE POSTION ADJUSTMENT OF BOTTOM TRIMMER VUTTING PARTS	下切刀組相關位置調整	19
24 · THE RELATIVE OSITION ADJUSTMENT OF BOTTOM TRIMMER	下切刀組、切線之相關位置	21
25 · THE RELATIVE POSITION OF NEEDLE, LOOPER THREAD AND BOTTOM TRIMMER	下切刀組與針線及下勾針線之關係	23
*General table-automatic (T1)	一般桌板-自動用 (T1)	
* General table-common (T2)	一般桌板-普通用 (T2)	
*Sinking style table- automatic (T3)	下沉式桌板-自動用 (T3)	
*Sinking style table- common (T4)	下沉式桌板-普通用 (T4)	

1. 請依本機所附之各式桌板裁製圖，根據實際上之需求，裁製正確桌板。

Before installing machine, please refer to table cut-out drawing to cut out table correctly.

2. 再依序安裝防震膠墊，或支撐架及其他副件。

According to the sequence of installation, fix quake-proof, base-fixed plate and other attachments.

\* 注意

Remarks

- (1) 一般桌板-

請依下圖所示順序安裝膠墊支架及防震墊。(圖 1)

- (1) General table-

According to the sequence of Fig.1, install quake-proof Rubber Cushion and the frame of the Cushion. (Fig.1)

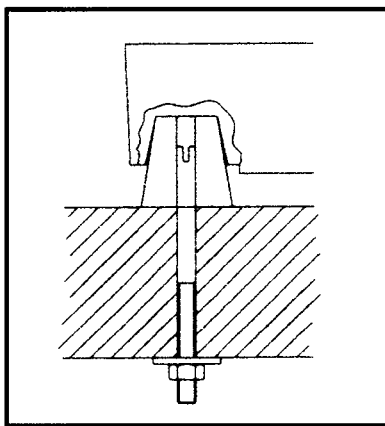

Fig.1

- (2) 下沉式桌板-

請依下圖所示確實安裝機台支架，在安裝膠墊支架及防震膠墊。(圖 2)

- (2) Sinking style table-

According to Fig.2 install the machine frame, and again to install the quake-proof Rubber Cushion and the frame of the Cushion. (Fig.2)

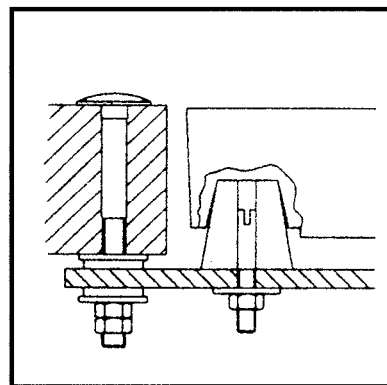

Fig.2

3. 馬達之轉向為順時鐘方向，皮帶之鬆緊度以用手指向內壓 2cm 為一般標準，同時為了安全起見，請將上、下皮帶蓋蓋上。

Be sure that the Motor turning direction is clockwise, and the Motor Belt tension can be pressed with finger inward 2cm. For safety reason, please fasten the Belt Cover. (Fig.3)

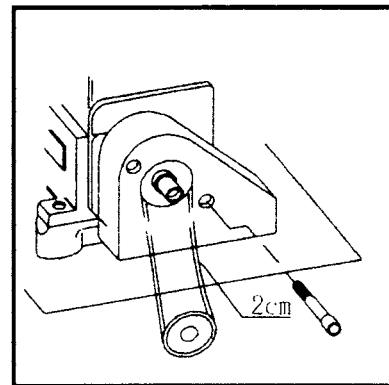

Fig.3

4. 皮帶輪想對轉速與皮帶尺寸請參照表 1。

本機最高的車縫速度為每分鐘 6000 轉，一般轉速為每分鐘 5500 轉(於裝上皮帶輪後，最高轉速為 4500 轉，一般轉速為 4000 轉)。爲了提高機台使用壽命，新機於開始使用的前 200 小時(約一個月)內，其轉速切勿超過每分鐘 5000 轉。(圖 4)驅動輪與皮帶

軸之轉向皆爲順時鐘方向。

For machine's long-life and durable operation, it is recommended that the maximum speed shouldn't exceed 80% of the speed listed on Table 1.

Make sure to choose the correct size of Motor Pulley and Belt.

The turning direction of Pulley (A) is clockwise like Handwheel (B). (Fig.4)

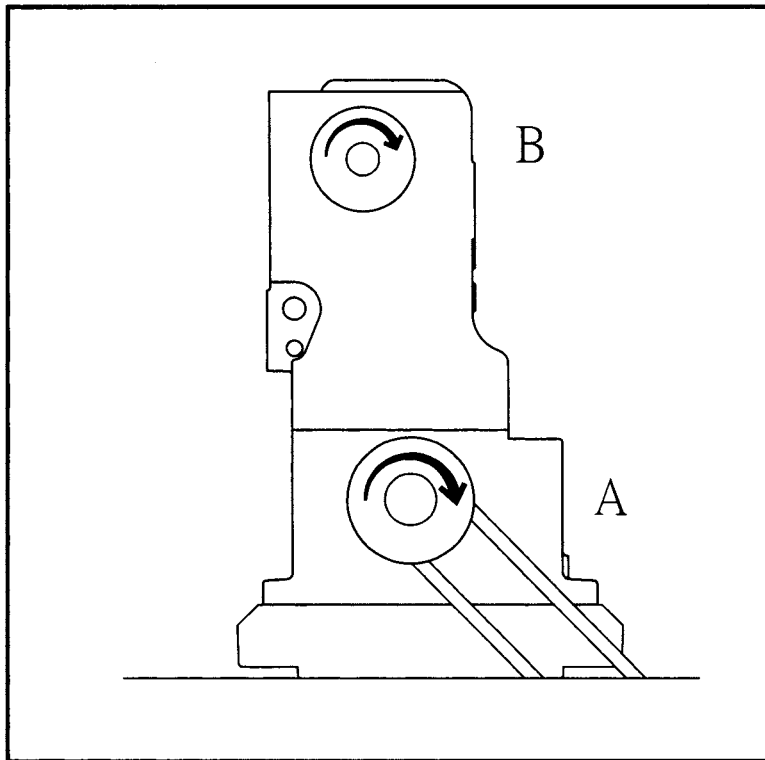

Fig.4

Table 1 (表 1)

Machine speed (s.p.m) 轉速/分	Motor pulley Outer Diameter (mm)		Motor Belt V-BELT,M-TYPE (CLUTCH MOTOR)
	60HZ	50HZ	
6000	105	120	36" ↑ 35" ↓ 34"
5500	95	115	
5000	85	105	
4500	80	95	
4000	70	85	

## 2. 馬達與皮帶

## MOTOR AND BELT

1. 請依照表 1 所指示之規格安裝達，並使用 M 番之 V 型皮帶。  
安裝馬達時，馬達驅動輪與機器皮帶輪之中心點須呈一直線。而在使用離合器馬達時，所謂馬達驅動輪與機器皮帶輪之中心點呈一直線，是指離合器馬達驅動輪，因起動踏板下踩而向左靠列底的狀態下。(圖 5)

Use Clutch Motor and V-Belt of M-type.

Position Motor so that its center aligns with the center of machine's Pulley when the Pulley is shifted to the left by treading Pedal. (Fig.5)

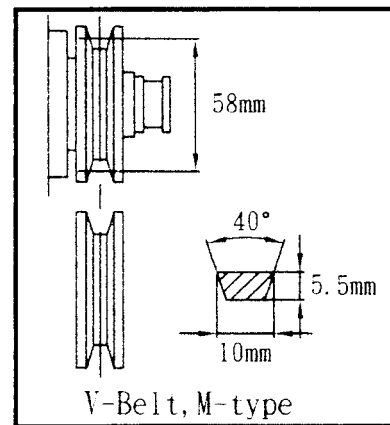

Fig.5

## 3. 潤滑油

## LUBRICATION OIL

1. 請選用與 Mobil #10 或 Esso #32 同級之潤滑油。  
Please use oil Mobil #10, Esso #32 or its equivalent.
2. 在新機使用前請先注入潤滑油。旋開頂蓋上的噴油檢視蓋(A)，將油緩緩注入機器中，待油滿至油量指示窗(B)上下線之間即可。(圖 6)  
As the oil has been completely drained before shipment, please fill lubrication oil first before the new machine to be used.

To remove Oil Sight Window Plug A and fill the oil slowly until the oil level reach between lines H and L of

Sight Gauge B. (Fig.6)

3. 於每天開機操作時，請先檢查油狀態是否正常且注意油量是否低於指示窗之下限，若低於下限請隨時補充新油。

When you begin operating the machine everyday, please check whether all the lubricating system is in good condition.

If oil is lower under L line of Oil Sight Gauge B, please supply oil. (Fig.6)

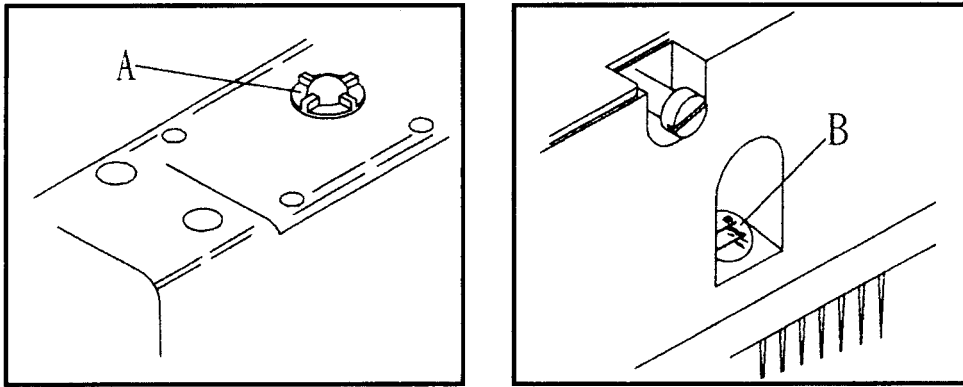

Fig.6

#### 4·潤滑油的更換

為延長本機的使用壽命，請於開始用後的一個月內更換第一次新油，以後約每六個月更換一次。

更換潤滑油時，請先取下 V 型皮帶，再將機器自工作檯取下。先卸下放油螺絲(A)，並倒乾油槽內之舊油，此時，注意勿污染 V 型皮帶。待舊油完全排出後，再將放油螺絲鎖緊，再依 C-2 的步驟注入新油。(圖 7)

For machine long-life and durable performance, please replenish lubricating oil after one-month

#### CHANGE OF LUBRICATION OIL

operation and it must be completely changed every six months thereafter.

Please remove V-belt from Pulley and remove machine from Table. After removing Screw A and draining all the used oil from the Reservoir.

When you replenish new oil, take care not to smear V-Belt with oil then tighten Screw without fail. (Fig.7)

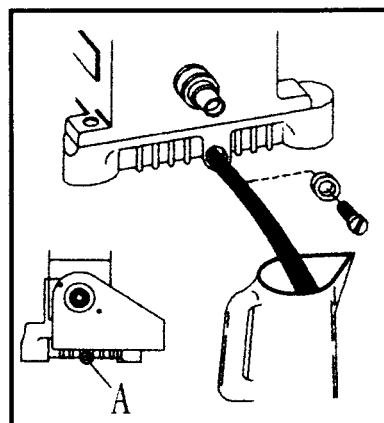

Fig.7

## 5 · 濾油器之更換

## REPLACING OIL FILTER

本機裝有濾油器，新機使用一個月後必須更換新品。此後，約每六個月更換一次。(圖 8)

The machine is equipped with and Oil Filter as Fig.8, when Oil Filter gets clogged with dirt, the proper lubrication is impossible.

Therefore, please change Oil Filter after one month initial operation and please change Oil Filter every six months thereafter. (Fig.8)

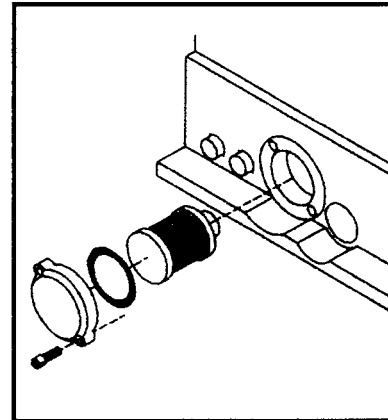

Fig.8

## 6 · 擊針的選用及更換方式

## HOW TO REPLACE THE NEEDLES

1. 本機使用編號 UY/128DAS 的各式大、小番號擊針或其他相同規格的产品。

Please use all kinds of the model number UY/128GAS of Organ's needle or its equivalent.

2. 在更換擊針時，請先旋開鎖針螺絲(A)，並取下舊針，再依車縫布料厚薄、質料，選定最合適之擊針，將新針插至針鑷之最頂端，且使長溝面背向自己。(圖 9)

When replacing new needles, loosen Screw A, then pull out the used needles, insert the new ones into the hole of Needle Holder as far as they can go and adjust the Needle Scarf facing rearwards from operator's

view. (Fig.9)

3. 重新將鎖針螺絲鎖緊(A)  
Fasten screw(A)

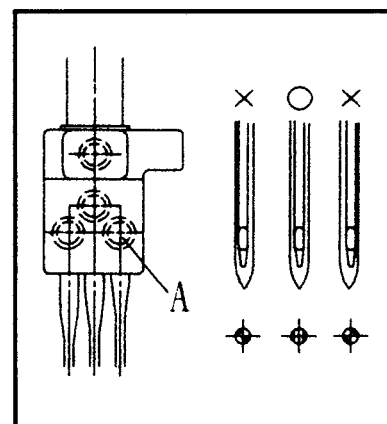

Fig.9

## 7. 穿線方式

## THREADING

1. 請按照圖中所指示的穿線方式，正確穿線。若穿線方式錯誤，將會引起斷線，跳針或車縫不平等現象。

Please refer to Fig.10. for treading.  
Wrong threading may cause thread breakage, stitch skipping, puckering, uneven seam, ect.

2. A,B,C...擊針線

D...上裝飾線

E...下勾針線。(圖 10)

A,B,C...are needle threads

D...is top covering thread

E...is looper thread

3. 若用三針車縫，則穿線方式如圖所示。若用二針車縫，穿線方式亦相同，所不同者，僅是擊針線穿二針而已。(圖 10)

The illustration Fig.10. Shows the threading for 3-Needle Machine.

When cotton or nylon threads is used as looper thread, the thread should go through Fig. 10-a as show.

4. 當下勾針線使用棉線或伸縮尼龍線時，其穿線方法並不相同，請參照圖 10-a 中的正確方式穿線。

When wooly, nylon or similar thread is used as looper thread, please refer to Fig. 10-a for threading.

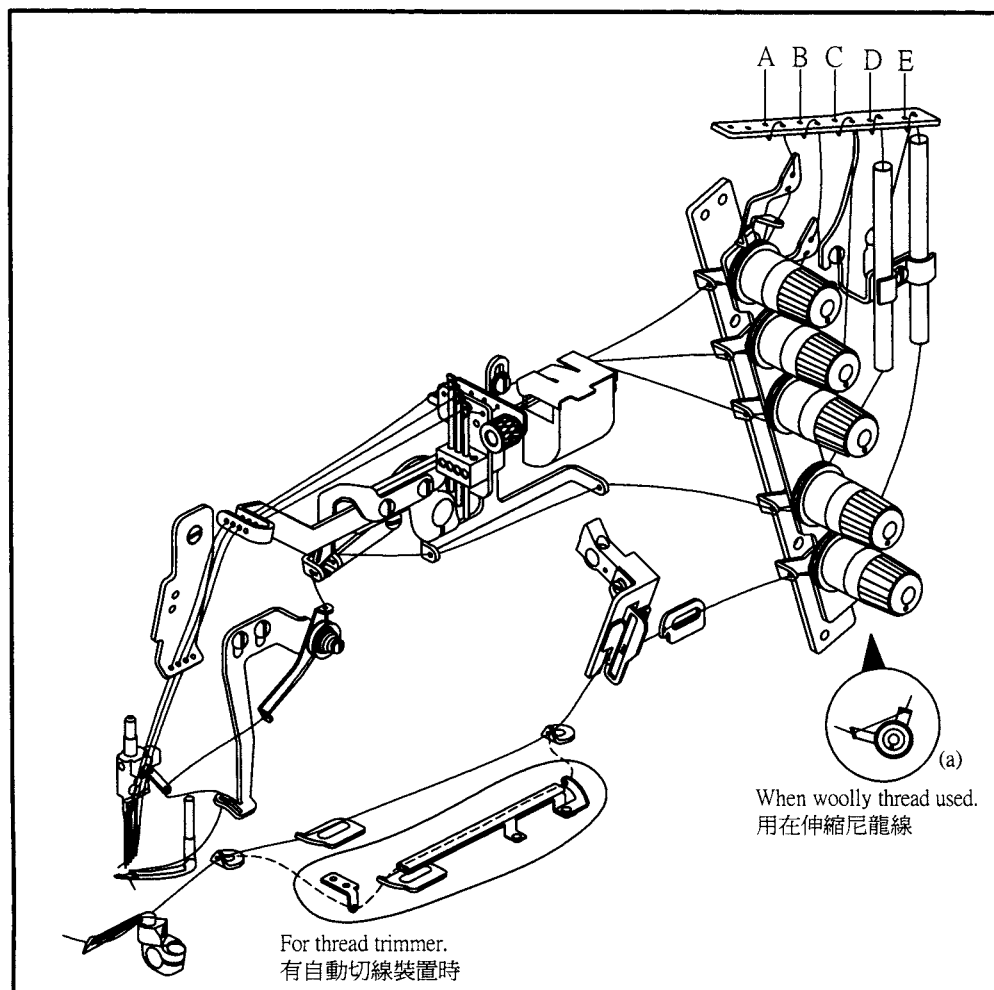

Fig.10

## 8 · 拉線鬆緊度的調整

## ADJUSTING THREAD TENSION

拉線的強弱必須根據車縫的布料、厚薄及線與針距的不同，而做調整，將針線控制鈕順時鐘方向旋轉時，線愈緊，反之則愈鬆。

The tension of the thread depends on

1. The material and the thickness of the fabric to be sewn ;
2. The threads to be used.
3. The stitch width, stitch length, etc.

If you turn the Thread Tension Spring Cap clockwise, thread will be tighter, on contrary, it will be looser.

Make the thread tension as weak as possible according to the sewing condition as long as stale seam can be obtained.

## 9 · 上飾線控線桿的調整

### ADJUSTING OF TOP COVER THREAD EYELET

1. 除針線控制鈕可調整上飾線之張力外，上飾線過線桿①亦可調整上飾線之鬆緊(圖 11)，鬆開固定螺絲②，將上飾線線桿下移，可將上飾線放鬆，反之，則可將上飾線收緊。
2. 當針線控制桿向左下方傾斜大一點，則可將上飾線放鬆，反之則可將上線收緊。

The tension of top cover thread also can be adjusted by loosening screw② then moving Top Cover Thread Eyelet① upward or downward. (Fig.12)

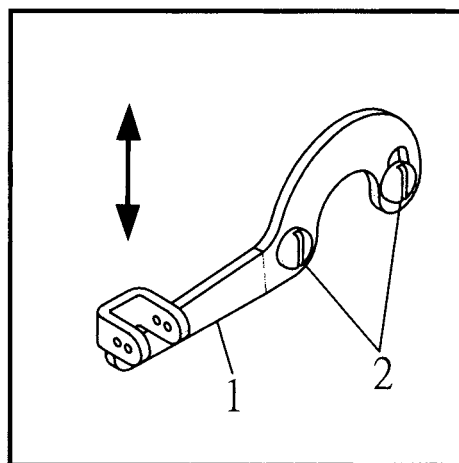

Fig.11



## 10 · 壓腳的調整

## ADJUSTING PRESSER FOOT

鬆開壓腳固定螺絲①左右搖動，調整押腳，使針尖位於押腳針孔的正中央，調整好後，再將固定螺絲鎖緊。(圖 12)

Loosen screw① and adjust Presser Foot left and right to a proper position where the needles can get into the center of Presser Foot eyelets.

After adjusting, tighten screw①. (Fig.12)

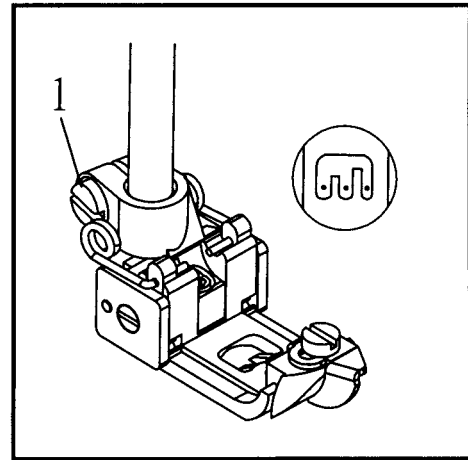

Fig.12

## 11 · 壓腳壓力強度的調整

## ADJUSTING PRESSURE OF PRESSER FOOT

1. 若要求布料車縫順暢且縫合完美，押腳壓力應盡量輕些。

Adjust Presser Foot Pressure as weak as possible, so that cloth can be sewn smoothly.

2. 鬆開螺帽(A)，轉動螺絲(B)，待其調整至適當壓力後再將螺帽(A)鎖緊。(圖 13)

To adjust, loosen nut A, turn screw B to a proper pressure, then fasten nut A. (Fig.13)

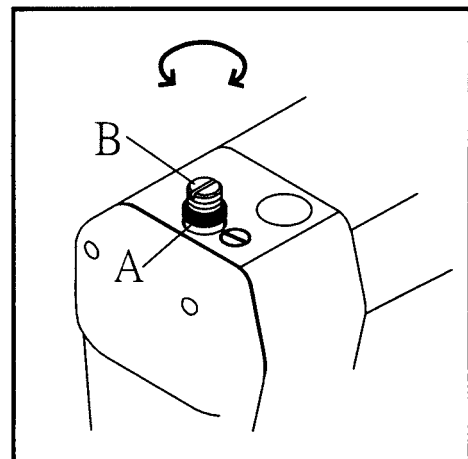

Fig.13

## 12· 縫目長度的調整

本機的標準縫目為最粗針 1 英吋約 7 針，最細針 1 英吋約 15 針，採用無階段式調整。

Stitch length can be adjusted in any range from 1.7mm~3.6mm or 7-15stitches per inch.

1. 將針距調整鈕順時鐘方向旋轉時，則縫目愈密，反之則縫目愈疏。(圖 14)

Turn Knob ① clockwise, the stitch length becomes short, on contrary, it becomes long. (Fig.14)

## ADJUSTING STITCH LENGTH

2. 本機可於機器轉狀態下，旋轉針距調整鈕調整縫目長度，不須停機。  
You can adjust the stitch length at ease when machine is being operated. There is no need to stop the machine.

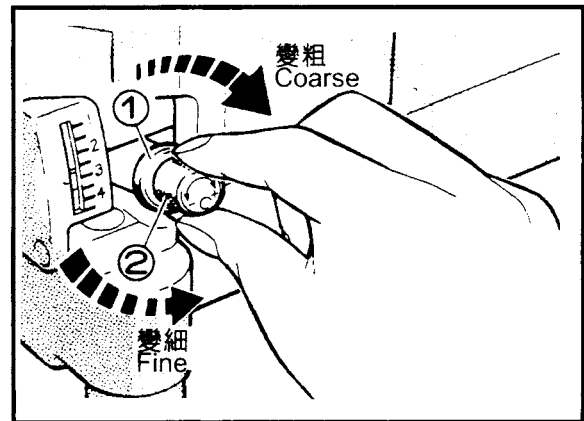

Fig.14

## 13· 差動比的調整

## ADJUSTING DIFFERENTIAL FEED RATIO

1. 本機之差動比可從 1 : 1 調整至 1 : 5.6。

The differential feed ratio of this machine is adjustable from 1 : 1 to 1 : 5.6.

2. 機台左方一驅臂(A)向下調整時，差動比小，向上時則大。調整差動比前將螺絲(B)鬆開，調整後再鎖緊。(圖 15)當差動齒比主齒傳動速度快，可摺景車縫，反之。當差動齒比主齒傳動速度慢，可做伸展布料車縫使用。

Loosen Knob B, then press Arm A clockwise to decrease the differential ratio feeding for stretching the fabric(differential ratio feeding moves slower than the mail feed dog) On

contrary, turn Arm A counter-clockwise to increase the differential ratio feeding for gathering the fabric(differential ratio feeding moves faster than the mail feed dog) (Fig.15)

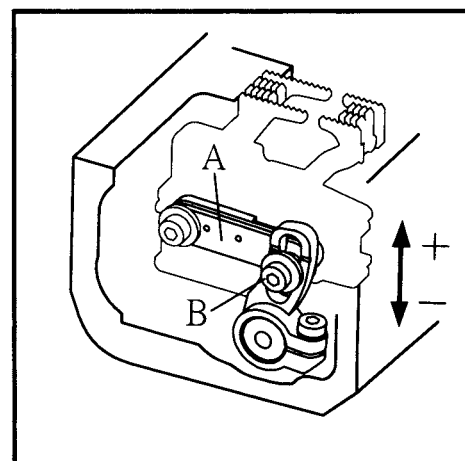

Fig.15

## 14 · 針棒高度的調整

### ADJUSTING THE HEIGHT OF NEEDLE BAR

1. 當針棒移動到最高點時，左針尖端與針板距離如附表 2，為針棒之標準高度。

When the Needle Bar is on the top position, the distance between the Left Needle tip and Stitch Plate should be as table 2.

This is the standard height of Needle Bar.

table 2

規格種類 Needle Gauge	左針高度(mm) Height of Left Needle
240	7.8
248	7.8
356	8
364	7.6

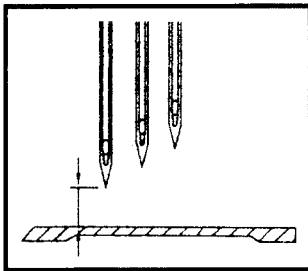

2. 若要調整針棒高度，請取下止油膠蓋，放鬆針棒連桿(A)上的螺絲(B)，上下調整針棒的高度後在固定之。(圖 16)

To adjust the height of Needle Bar, remove the Rubber Seal Plug and loosen the screw B or down to the required height and fix the screw B. (Fig.16)

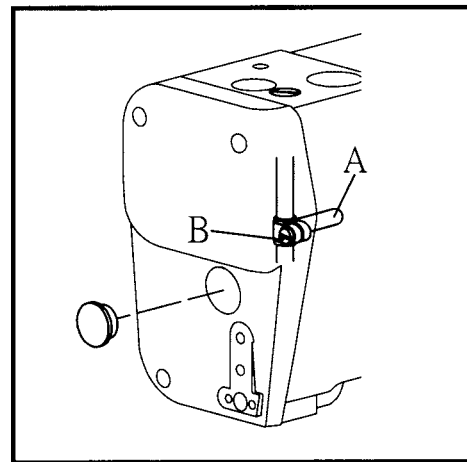

Fig.16

3. 當下勾針向左前進與最長針(左針)對齊時，勾針針尖底部與針孔上沿距離 1mm，此一相對位置即為本機針棒之標準高度。(圖 17)

When the Loper goes through the Left Needle, the Loper tip is 1.0 mm above the upper end of the Left Needle hole. (Fig.17)

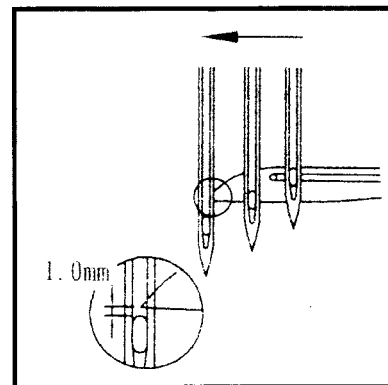

Fig.17

## 15 · 針與勾針位置的說明 POSITION OF NEEDLE AND LOOPER

1. 將勾針固定於勾針座上，勾針約向前(向操作者方向)偏 0.6mm~0.8mm。(圖 18)

Insert the Looper into the Looper Holder as far as it can go and deflect the Looper to the front about 0.6mm~0.8mm. (Fig.18)

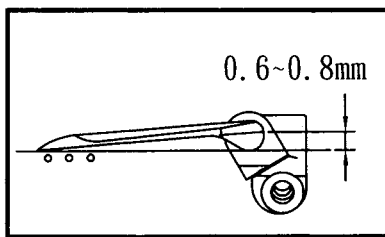

Fig.18

2. 再將針棒降至最低，且下勾針退至右孔點，此時最短針(右針)與下針針尖的距離為 2.7mm~2.8mm、不同針距，請參照表 3 做調整。(圖 19)  
To move the Needle Bar to the lowest position, at the same time, the Looper returns to the extreme right end, the distance between Right Needle and the looper tip is 2.7mm~2.8mm. (Fig19)

Pease refer Table 3 for other Needle gauge's adjustment

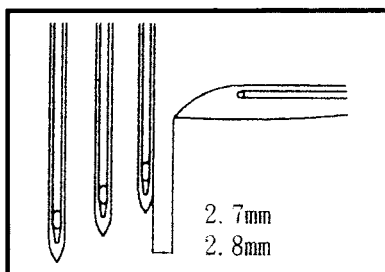

Fig.19

Table 3

Needle Gauge	Movement of Looper the Right
4.0mm (A)	3.2mm
4.8mm (B)	3.2mm
5.6mm (C)	2.7~2.8mm
6.4mm (D)	2.5mm

### \* 注意

### Remarks

針必須完全插入針鑄孔中。經過調整後，必須確定每一根針是通過針樣針孔的正中央。(圖 20)

Insert the Needles into the Holder as far as they can go.

After the adjustment, make sure the needles can get into the center of the Needle Plate holes, and the gaps are even. (Fig.20)

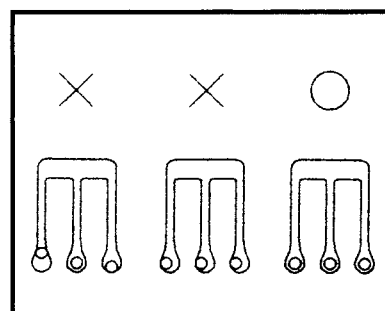

Fig.20

## 16 · 針與勾針的時位關係調整

### ADJUSTING TIMING RELATION BETWEEN NEEDLES AND LOOPER

1. 當勾針向左前進通過右針時，勾針針尖與針應輕微接觸

0.03mm~0.05mm。(圖 21)

When the Looper moves from extreme right and forward to the Right Needle, the Looper tip shall slightly contact the Needle by 0.03mm~0.05mm. (Fig.21)

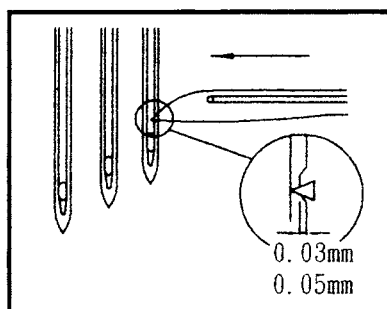

Fig.21

2. 當勾針向左前進通過左針時，勾針針尖與針的針距為 0.15~0.20mm。(圖 22)

When the Looper moves to the Left Needle, the clearance is about 0.15mm~0.20mm. (Fig.22)

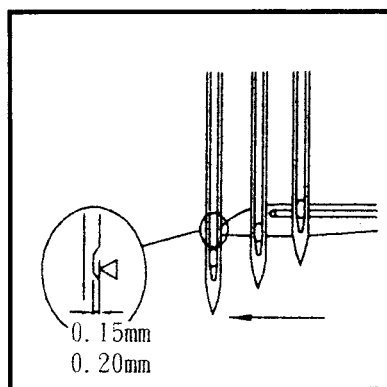

Fig.22

3. 當勾針向右退後，左針必須插到勾針斜面積線往上 0.3mm~0.4mm (如圖 23)且當最長針針尖與勾針底部

平齊時，勾針針孔中心到左針的距離為 1.5mm~2.0mm。(圖 24)

When the Looper moves backward to left Needle, the Left Needle tip should stick on the slant edge of the Looper by 0.3mm~0.4mm. (Fig.23)

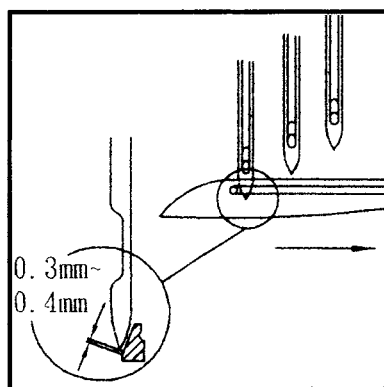

Fig.23

When bottom surface of the Looper aligns with the tip of Left Needle, the distance from the center of Looper hole to Left Needle edge is about 1.5mm~2.0mm. (Fig.24)

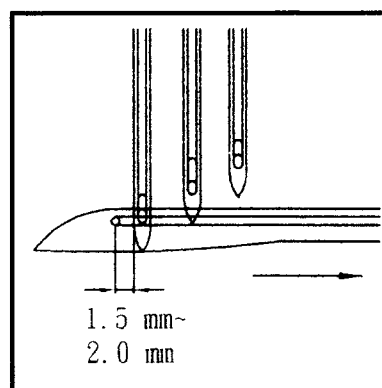

Fig.24

## \* 注意

## Remarks

若欲調整擊針插到勾針斜面之厚、薄，請先將縫製平台，曲軸室上蓋及曲軸室製墊片取下，再放鬆下勾針驅動軸導槽旁的搖臂調整銷鎖上的螺絲(A)，將螺絲往前(操作者方向)推動鎖緊，則擊針插到斜面之寬度減少，反之(圖 25)則愈來愈厚。

To adjust feeding amount of the needle sticking on the looper slant edge (Fig.24), please take off Crank Chamber Cover and Crank Chamber Gasket from the Cloth Plate by adjusting the Screw of Looper Bar Guide A.

Turn screw A to operator's direction to fasten, the feeding amount will be less on contrary, it becomes more.

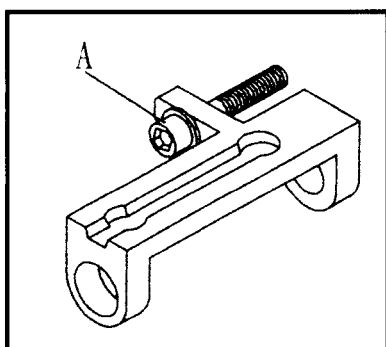

4. 當勾針向右退後經過中針時，此時勾針之針孔與中針的針孔成一直線。(圖 25)

When the Looper goes backward to the Middle Needle, the hole of the looper shall align with the hole of the Middle needle. (Fig.25)

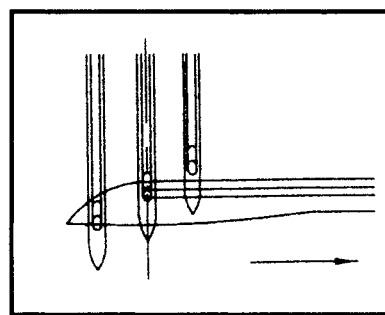

Fig.25

## \* 注意

## Remarks

若欲調整針運轉時間，請先將上蓋取下，放鬆上主軸鏈輪上的螺絲(A)，另一手握住手推輪使其不動，此時將主軸鏈輪往前(操作者方向)推動，則求針運轉時間延後，反之，則勾針時間提早。(圖 26)

To adjust the Looper's orbit movement, please open Top Cover and Loosen the 4 Screws of Upper Shaft Sprocket(A) then hold Hand Wheel still.

When slightly turn Shaft Sprocket to operator's direction, the Looper's movement will be delay, on the contrary, it will be expedised. (Fig.26)

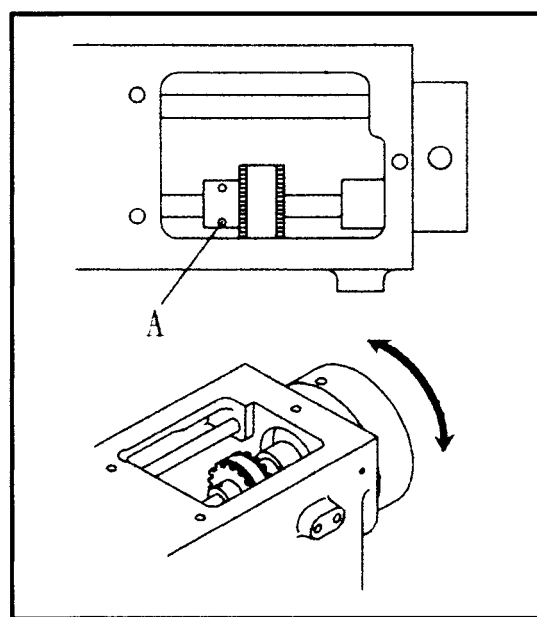

Fig.26

## 17 · 頂針片高度之調整

### ADJUSTING THE HEIGHT OF REAR NEEDLE GUARD

1. 當針棒降至最低時，後頂針片上之稜線(A)與之跟針孔成一直線。(圖 27)

When the Needle Bar hoes down to the lowest position, the line A of the Rear Needle Guard should be at the center of needles holes. (Fig.27)

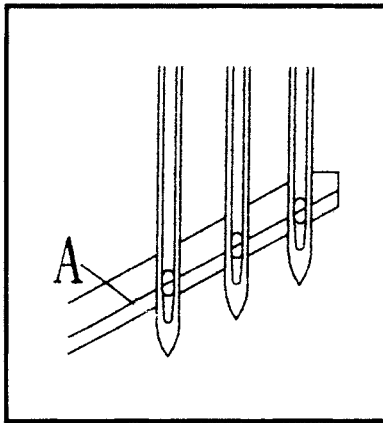

Fig.27

2. 若欲調整頂針片的高度，請放鬆螺絲(B)、(C)調整之，但切勿調得太高，以免撞及送料具。(圖 28)

Loosen screw B and C for above adjustment.

Caution : Never adjust the Needle Guard too high to contact Feeding Device. (Fig.28)

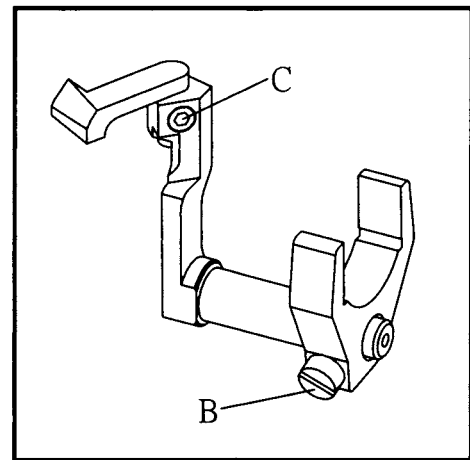

Fig.28

## 18 · 前後頂針片之調整

### ADJUSTING FRONT AND REAR NEEDLE GUARD

1. 當勾針針尖左前進，針尖到達右針中心時，此時後頂針片與右針之距離為 0~0.05mm。而當勾針針尖到達左針中心時，後頂針片與左針之距離亦為 0~0.05mm。(圖 29)

When Loper tip comes near to the center of Right Needle, make a clearance between Right Needle and Loper 0~0.05 mm by actuating Needle Guard (rear), and adjust a clearance between Left needle and Guard (rear) 0~0.05 mm. (Fig.29)

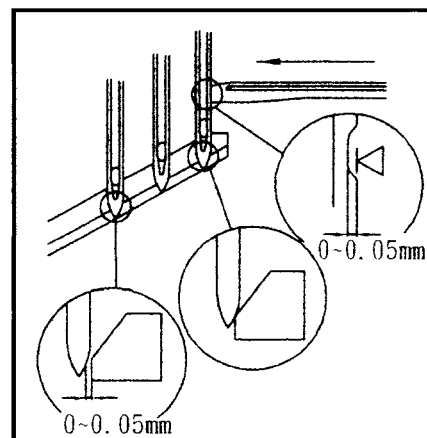

Fig.29

- 當勾針針尖向前進，針尖到達左針中心點時，前頂針片約高於右針 1.5mm~2.0mm(圖 30)，且左針與前頂針片的距離為 0~0.3mm，當針針尖退後針尖到達右針中心點時，前頂針片與右針之距離為 0~0.3mm。(圖 31)

When Looper tip shifts the center of Left Needle, set the Front Needle Guard 1.5mm~2.0mm higher than the Left Needle tip. The clearance is 0~0.3mm between Left Needle, Right Needle and Front Needle Guard. (fig.30&31)

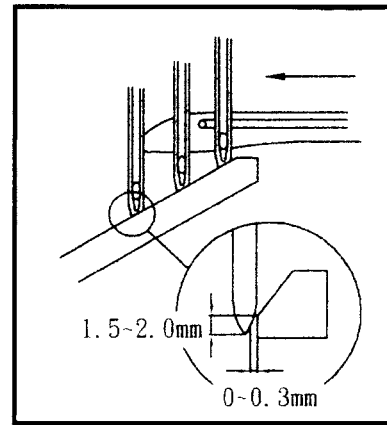

Fig.30

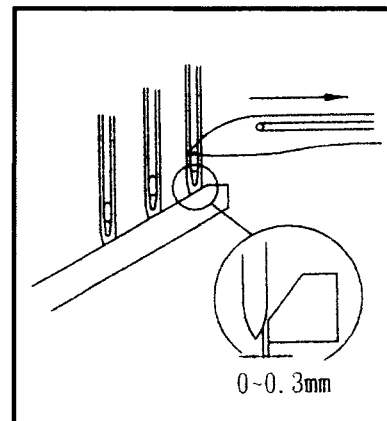

Fig.31

## 19 · 送布齒高度調整 ADJUSTING THE HEIGHT OF FEED DOG

- 當送布齒在最高點位置時，送布齒齒尖面與針板面平行，此時主送布齒 A 與差動送布齒 B 高度相同且齒面與針板面差 1.2~1.5mm。(圖 32)

When Feed Dog are at the highest position, the surface of Fed Dog and the surface of Stitch Plate becomes parallel with each other.

from surface of Stitch Plate to the surface of Feed Dog to be 1.2~1.5mm. (Fig.32)

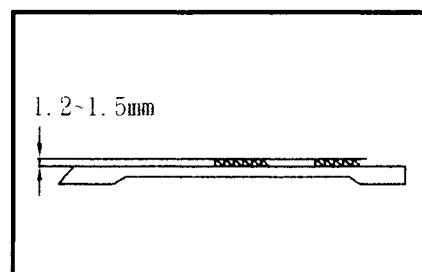

Fig.32

At this time, make differential feed dog (A) and main feed dog (B) to be at the same height and adjust the distance



## 20 · 上叉位置的設定

### ADJUSTING THE POSITION OF THE SPREADER

1. 當勾線針(A)向左游走時，其上(B)點之位置與最左車針間之隙應為0.5mm~0.8mm，且當勾針線(A)游走至最左位置時，其上(B)點與最左邊車針之間隙一定得在4.5mm~5.5mm 之間。(圖 33)

When Spreader (A) move from right to left, provide a clearance of 0.5~0.8mm, between Left Needle and the tip (B) of thread hooking point, and when it comes to the extreme left, the clearance between the center of Left Needle and tip (B) of tread hooking point must be 4.5~5.5mm. (Fig.33)

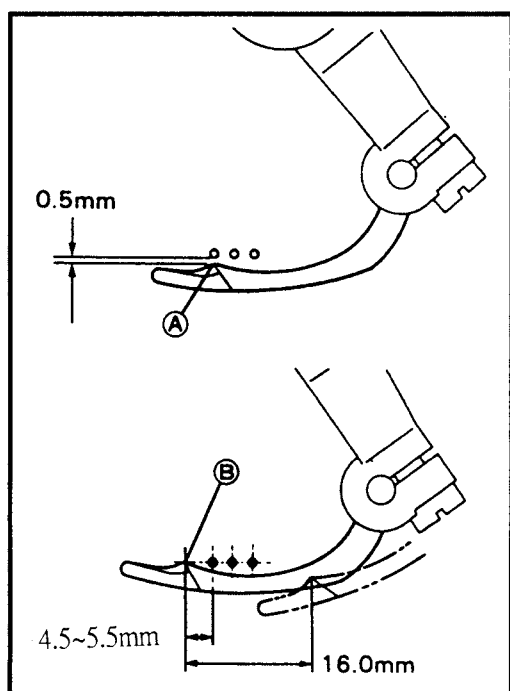

Fig.33

2. 勾線針下緣之高度應保持在針板面之上 8.3~8.7mm。  
Adjust the height of undersurface of Spreader (A) above the top surface of Stitch Plate to be 8.3~8.7mm (Fig.34)

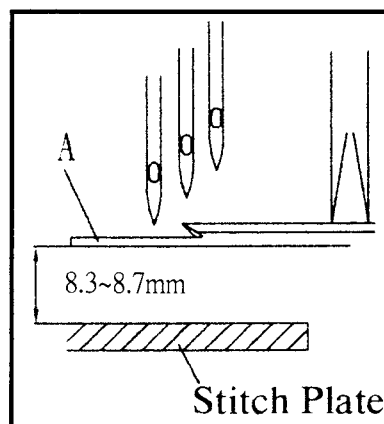

Fig.34

3. 上述之調整動作可藉由放鬆螺絲⑭與⑮來取得。  
Above adjustment is made by loosening Screw ⑭ of Spreader and Screw ⑮ of Spreader Holder. (Fig.35)

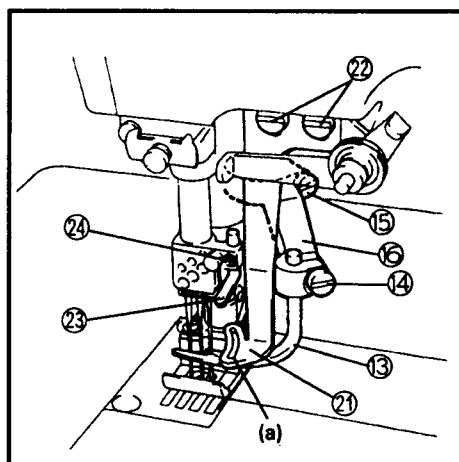

Fig.35

4. 根據所使用之線的不同，必須將車針其勾線針的間隙作以上正確之調整。  
The above adjustments should be made properly according to the thread to be used.

## 21 · 上飾線之導線器的固定

### FIXING OF TOP COVER THRED GUIDE & TOP COVER THREAD EYELET

1. 當勾線針退至最右位置而能平隱的勾住線時，上飾線之導線器①的下緣與彎針⑬的上緣之間間隙應為0.5mm。調整完畢後，鎖緊螺絲②。(圖 36)

Provide a clearance of 0.5mm, between undersurface to Top Cover Thread Guide ① and the top surface of Spreader ⑬.

At the position, the thread is caught smoothly by thread hooking part when spreader comes to extreme right, tighten screw ②. (Fig.36)

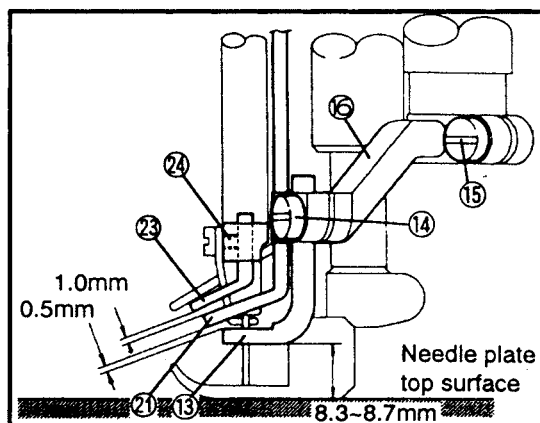

Fig.36

2. 線導線器①之上緣與上飾線穿線孔器③之下緣間之間隙應為1.0mm；同時穿線孔器③之線孔應與導線器①之長形孔延伸部份在一直線上。調整完畢後，鎖緊螺絲④。(圖 36)

Provide a clearance of 1.0mm, between top surface of Top Cover Thread Guide ① and undersurface of Top Cover Thread Eyelet ③.

Set the hole of Top Cover Thread Eyelet on the extension line of slot of Top Cover Thread Guide, then tighten screw 24. (Fig.36)

※ 根據所使用之線的不同，而必須將上飾線導線器，穿孔器位置作以上正確之調整。

※ The above (1),(2) should be adjusted properly according as the thread to be used.

## 22 · 勾針控制線桿的位置

### THE POSITION OF LOOPER THREAD TAKE-UP

1. 從操作員左側觀察勾針控制線凸輪。(圖 38)  
(Fig.38) is viewed left side of operator.
2. 當針從最高處下降時，左針大約位於勾針後面之一半的位置時(圖 37) 勾針針線必須脫離凸輪之最高位置 (P)。(圖 38)  
When needle comes down from the highest position and the Left Needle tip reaches around 1/2 position of the looper, (Fig.37) the looper thread should come over the highest position (P) of the Cam. (Fig.38)
3. 調整螺絲①並調整之。  
Turn the screw ① for above adjustment.

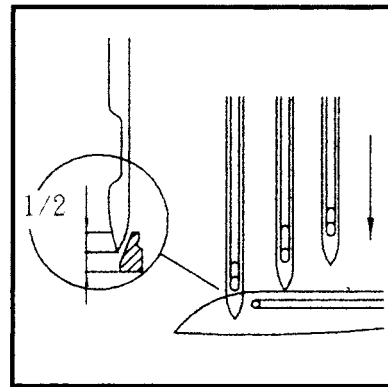

Fig.37

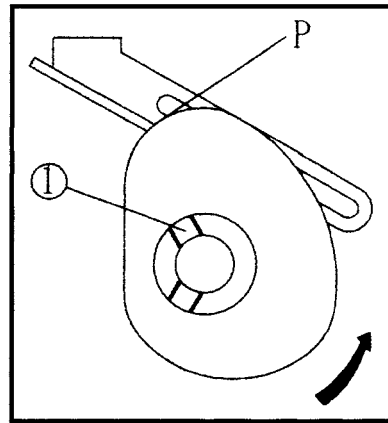

Fig.38

## 23 · 下切刀組相關位置調整

### THE RELATIVE POSITION ADJUSTMENT OF BOTTOM TRIMMER CUTTING PARTS

下切刀組安裝於機器前須先檢查切刀組之相關位置和滑順度及切線效果。Before you install the new Trimmer set into machine, please always to check the relative position, the situation of sliding and the trimming effect.

1. 當活動刀片往右移時，右邊刀口之尖端(A)與固定之前端(B)須對齊。且活動刀移至最右邊時，左邊刀口和固定刀前端的契合度為 1.0mm。調整時可放鬆螺絲(C)移動固定片。(圖 39)

When Lower Moving Knife move to the right, the Moving Knife hook (A) of right hand side one align with the tip (B) of Fixing Knife. When the Lower Moving Knife move to the right dead point, The Moving Knife hook of left hand side one pass the tip of Fixing knife in 1.0 mm. Loosen the screw (C) for adjusting the position of Fixing Knife. (Fig.39)

2. 夾線片(D)之邊沿須與活動刀右邊刀口內沿切齊，如(E)。可由螺絲(C)調整。壓力片(F)前端與固定刀前端之距離約為 1mm，調整時，可放鬆螺絲(G)，移動壓力片(F)。(圖 40)  
The edge of Clamp Spring (D) align with the inside edge of Moving Knife of right hand side hook (E). Please loosen the screw (C) to adjust the position of Clamp Spring and Fixing Knife. The distance between the top of Clamp Spring Pressure and top of Fixing Knife is about 1 mm. Please

loosen the screw (G) to adjust the position of Clamp Spring Pressure. (Fig.40)

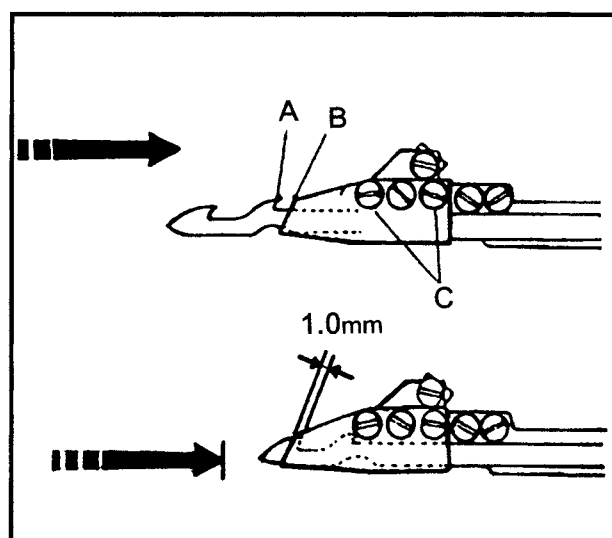

Fig.39

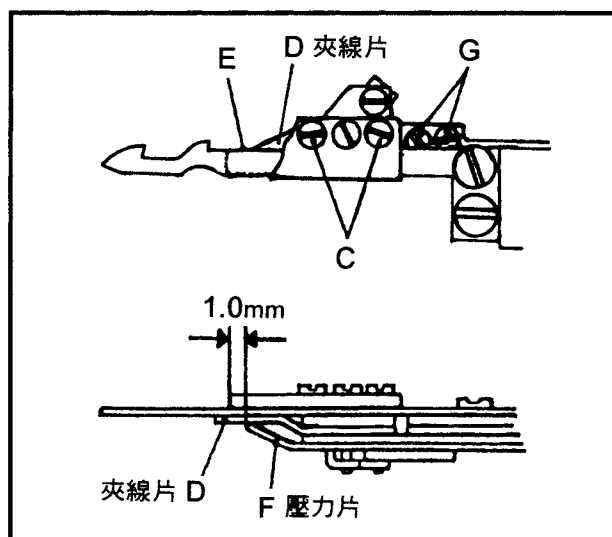

Fig.40

3. 夾線彈簧片的壓力調整---

當下勾針線被斷後，下針這端之線頭須被夾線彈簧片與活動刀片穩定夾住。調節夾線彈簧之壓力，可由螺絲(H)旋轉調整。(順時鐘方向壓力愈強，反時鐘方向壓力變弱)。

(圖 41)

When the looper thread has been cut off, the Clamp Spring and Moving Knife will clip the thread in stable. To increase the pressure of clipping thread turn the screw (H) clockwise and decrease the pressure turn the screw (H) counter-clockwise.

(Fig.41)

\* 注意

Remarks

夾線彈簧片之壓力調整須適中，壓力太強會減短活動刀片之壽命，壓力太弱則下勾針線頭易脫落。壓力之強度以能輕易切斷線即可。

The pressure of Clamp Spring must be moderate. If the pressure has been adjusted into too strong, it will decrease the life of Moving Knife. If the pressure has been adjusted into too weak, the looper thread will easy to lose from the Clamp Spring. What is moderate pressure? It is meaning that the pressure to cut the thread easily.

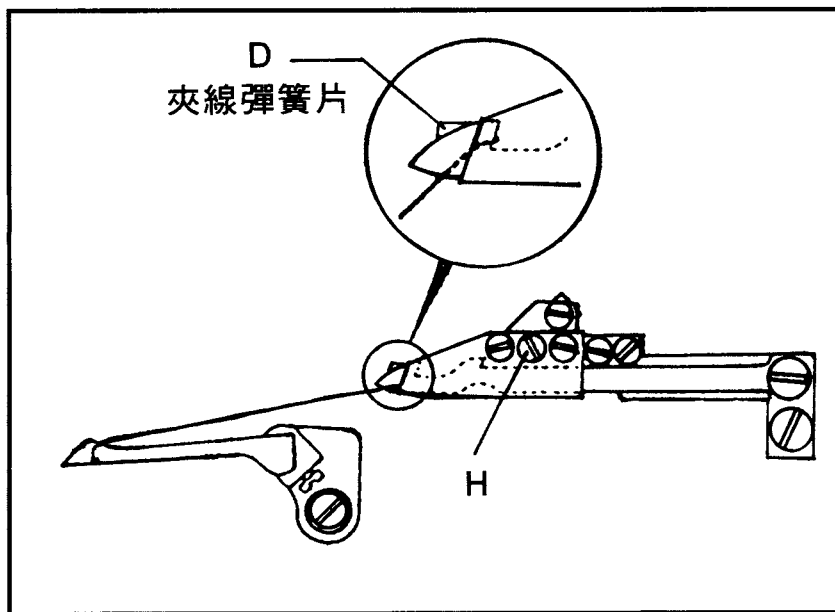

Fig.41

## 24 · 下切刀組、切線之相關位置

### THE RELATIVE POSITION ADJUSTMENT OF BOTTOM TRIMMER

#### 1. 下切刀組之前後位置---

當下切刀組由右定點移出至下勾針右側時(第一段動作),活動片之刀尖(A),約位於下勾針寬度中心,前、後 1/2 位置。(圖 42)

調整時可放鬆搖臂之偏心輪(B)上之螺絲(C),再轉動偏心輪,使活動刀片移到正確位置。

偏心輪上之記號(D)正常時,大約處於 3 點鐘方向位置。(圖 43)

#### The Front and Rear position of Bottom Trimmer---

When the trimmer moves out from right dead point to the right hand side of looper, (1st action) the tip of Moving Knife (A) aim the center of looper ridge. (Fig.42)

Please loose the screw (C) of Knife Guide Lever Eccentric Ring (B) and turn the Eccentric Ring for regulating the Moving Knife into right position. Please set up the mark (D) of Eccentric Ring to 3 o'clock position in ordinary. (Fig.43)

#### \* 注意

#### Remarks

當要調整偏心輪(B)改變切刀角度位置時,必須先放鬆下切刀托架導引片(E)上之螺絲(F),等調整好切刀組角度後再將導引片(E)輕輕靠在下切刀托架,鎖緊螺絲(F)。(圖 43)

When you would like to adjust the Eccentric Ring for changing the angle of under trimmer, please loose the screw (F) of Lower Knife Carrier Guide (E). Please

let the Lower Knife Carrier Guide (E) touch Lower knife Carrier in gently and lock the screw (F) down after the angle of trimmer have been adjusted. (Fig.43)

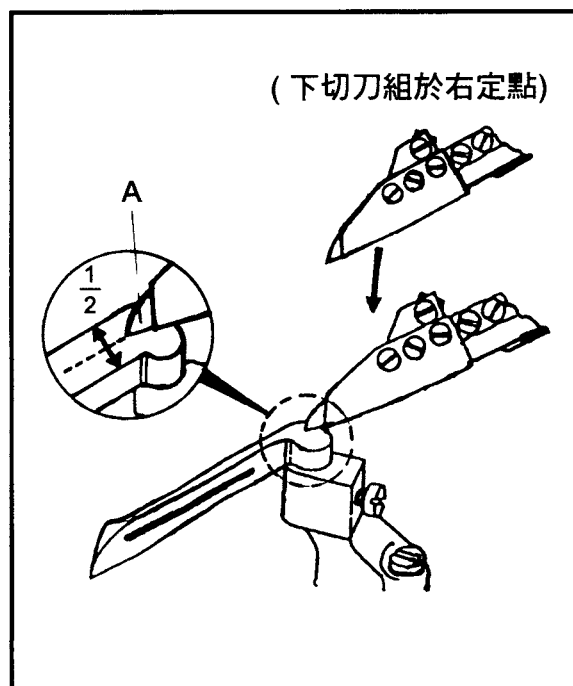

Fig.42

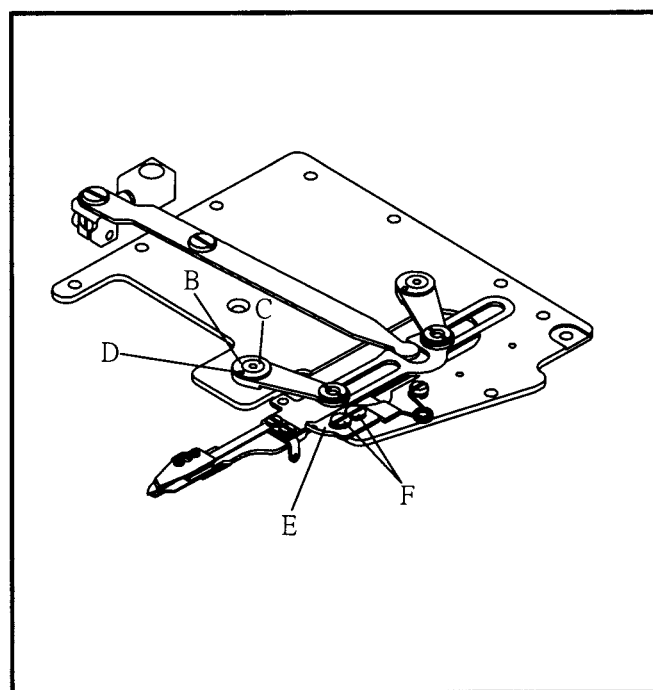

Fig.43

## 2. 下切刀組之左右位置---

當下切刀組之活動片(A)往左移至左定點時，活動刀(A)之刀尖，須超出下針(B)之左邊穿線孔約 1mm。(圖 44)調整時，可放越連結滑土(C)上的螺絲(D)，再用螺絲刀旋轉螺絲(E)，微調活動刀片左右位置至正確點後，再鎖緊螺絲(D)。(圖 45)

### The Right and left position of Bottom Trimmer---

When the Moving knife move to the left dead point, the tip of Moving knife has passed 1 mm over than the threading hole of loopr. (Fig.44)

When you would like to adjust the right & left position of Moving knife First, please loose the screw (D) of connecting Block (C), to turn the screw (E) by screwdriver for micro adjusting the correct right & left position of Moving Knife., then to locked the screw (D) down. (Fig.45)

### \* 注意

### Remarks

- 下切刀組完成調整時，須再次用時動移出活動刀片，確認相關位置是否正確，順暢。
- When you finish adjusted, please be moved the Bottom Trimmer by hand to confirm the relative position correctly & smoothly.
- 當必須調整下切刀組相關位置時，須確認針棒是否處於上定點，下勾針位於左定點(此為切線點)。
- When you adjust the relative position of Bottom Trimmer, please always confirm the needle bar in the top dead point & the looper in the

timing of cutting thread.

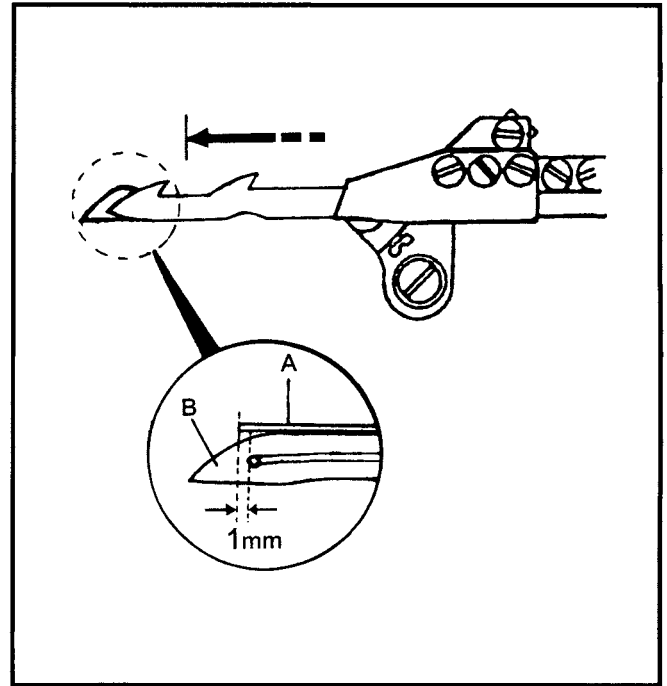

Fig.44

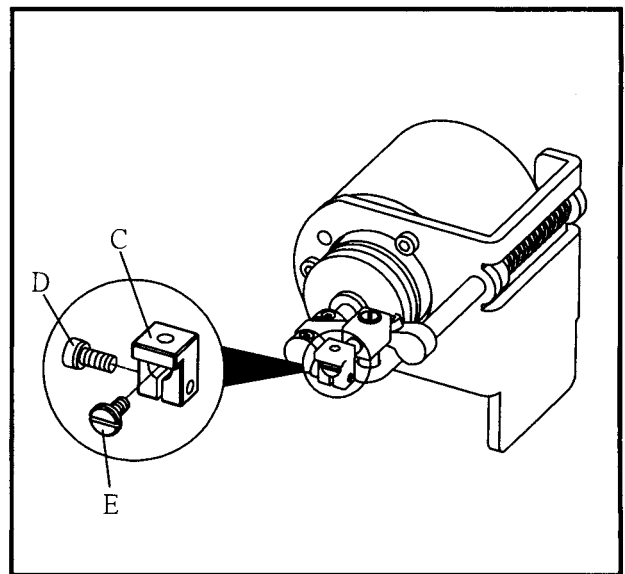

Fig.45

## 25 · 下切刀組與針線及下勾針線之關係

### THE RELATIVE POSITION OF NEEDLE, LOOPER THREAD AND BOTTOM TRIMMER

1. 當活動刀片(A)往左邊移時，必須通過針線之線環(B)。(圖 46-1)

When the Moving Knife (A) move to the left which must be passed the loop (B) of needle thread. (Fig.46-1)

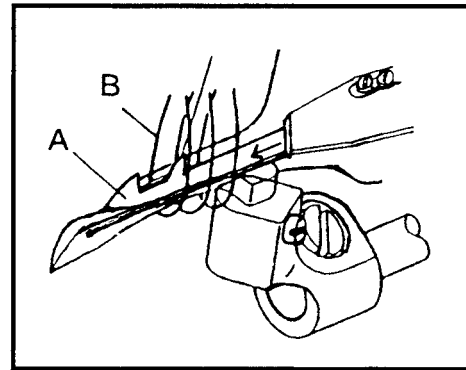

Fig.46-1

2. 當活動刀片往左移動至左定點時，下勾針線(C)須滑入活動刀片(A)之左邊刀口(D)內。(圖 46-2)

When the Moving knife move to the left dead point which looper thread must be dropped into the left hook (D) of Moving knife (A). (Fig.46-2)

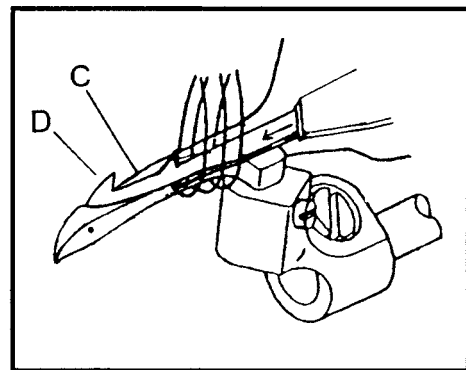

Fig.46-2

3. 活動刀片往右回移時，活動刀片右刀口須勾住針線，左刀口勾住下勾針線，一起往右拉回。(圖 46-3)

When the moving knife move to the right, the right hook of Moving Knife must hooks the needle thread and left hook must hooks the looper thread to pull into right side in same time. (Fig.46-3)

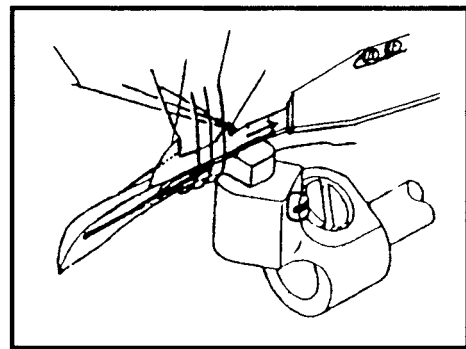

Fig.46-3

4. 針線及下勾針線由活動刀片拉回與固定刀切斷，針線切斷後自然脫落，下勾針線靠下針一端線頭須穩穩夾住於切刀。(圖 46-4)

The needle & looper thread are pulled back by Moving Knife and be cut by Fixing Knife. The needle thread must be cut in efficiently and looper thread has clipped by Bottom Trimmer in stably. (Fig.46-4)

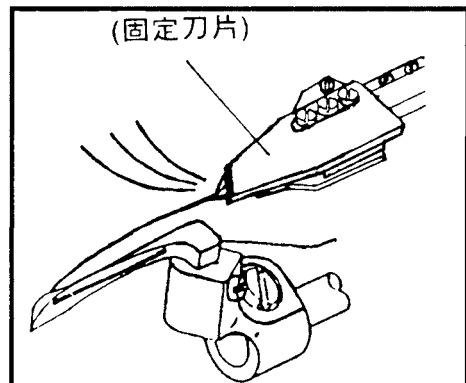
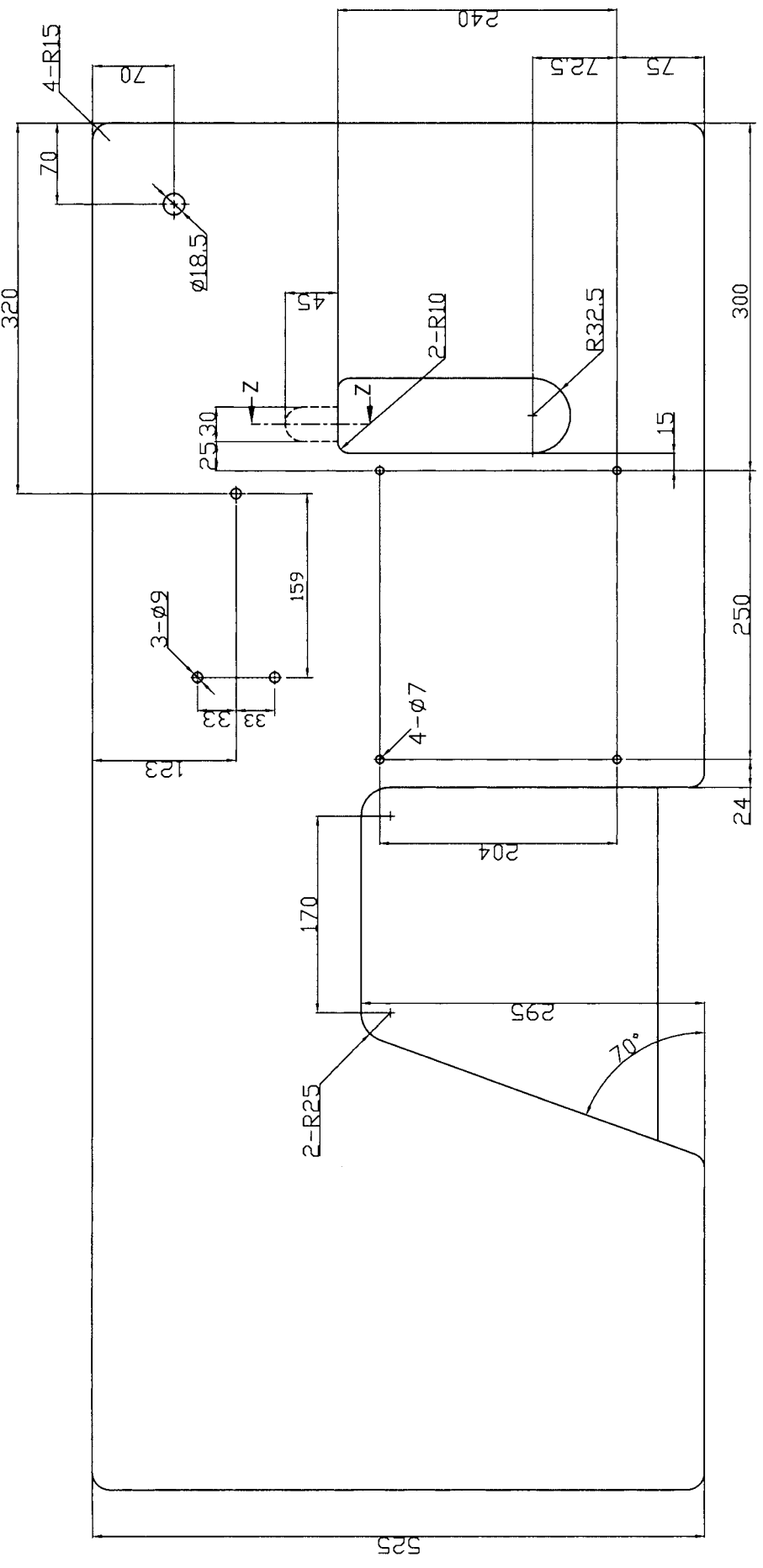
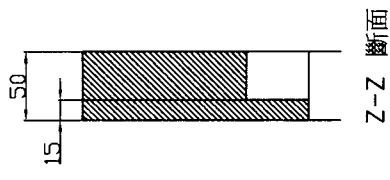

Fig.46-4





橫筒式三本車 (開口.平台式) - F機型-(安輪組) (普通)



--	--	--

Table No(桌板編號) : T2



